

OWNER'S GUIDE &

INSTALLATION INSTRUCTIONS

Thru-Hull, Depth

Transducer

Low Profile, Flush, and Retractable Models

01/26/11
17-006-01 rev. 11

WARNING: Always wear safety goggles and a dust mask when installing to avoid personal injury.

WARNING: Immediately check for leaks when the boat is placed in the water. Do not leave the boat unchecked for more than three hours. Even a small leak may allow considerable water to accumulate.

WARNING: Retractable models—The O-rings must be intact and well lubricated to make a watertight seal.

WARNING: Retractable models—Always attach the safety wire to prevent the insert or blanking plug from backing out in the unlikely event that the cap nut fails or is screwed on incorrectly.

WARNING: B117 and P319—Do not use the spacer if there is insufficient space to tighten the nut or it is within 11 mm (1/2") of the top of the housing.

WARNING: Stainless steel housing in metal hull—Be sure the washer contacts the hull. Do not tighten the hull nut with the washer against the isolation bushing, as the housing will not be firmly installed. If necessary, sand the isolation bushing until the washer rests against the hull.

CAUTION: Never pull, carry, or hold the transducer by its cable; this may sever internal connections.

CAUTION: Never use solvents. Cleaners, fuel, sealants, paint, and other products may contain strong solvents, such as acetone, which attack many plastics, greatly reducing their strength.

CAUTION: Plastic housing—Never use a fairing with a plastic housing; the protruding sensor would be vulnerable to damage from impact.

CAUTION: Metal housing—Never install a metal housing on a vessel with a positive ground system.

CAUTION: Stainless steel housing in metal hull—Stainless steel must be isolated from a metal hull to prevent electrolytic corrosion. Use the isolation bushing supplied.

IMPORTANT: Read the instructions completely before proceeding with the installation. These instructions supersede any other instructions in your instrument manual if they differ.

Record the information found on the cable tag for future reference.

Part No. _____ Date _____ Frequency _____ kHz

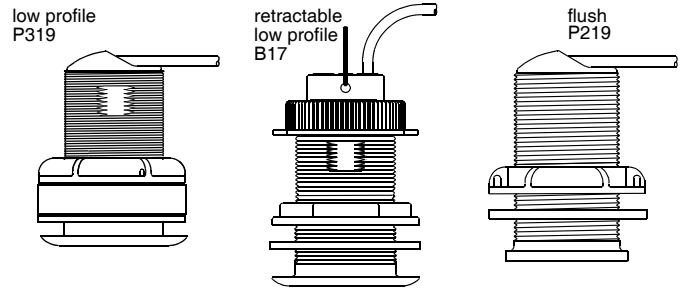

Applications

- **Plastic** housing recommended for fiberglass or metal hull only. *Never* install a plastic transducer in a wood hull, since swelling of the wood can possibly fracture the plastic.
- **Bronze** housing recommended for fiberglass or wood hull. *Never* install a bronze housing in an aluminum hull, because electrolytic corrosion will occur.
- **Stainless steel** housing compatible with all hull materials. Recommended for aluminum hull to prevent electrolytic corrosion *provided the stainless steel housing is isolated from the metal hull*.
- Accommodates up to a 20° deadrise angle.

Tools & Materials

- Safety goggles
- Dust mask
- Electric drill with 10mm (3/8") or larger chuck capacity
- Drill bit: 3mm or 1/8"
- Hole saw (see table opposite)
- Countersink tool (installing a flush housing)
- Sandpaper
- Mild household detergent or weak solvent (such as alcohol)
- File (installation in a metal hull)
- Marine sealant (suitable for below waterline)
- Additional washer [for aluminum hull less than 6mm (1/4") thick]
- Slip-joint pliers (installing a metal housing)
- Grommet(s) (some installations)
- Cable ties
- Water-based anti-fouling paint (**mandatory in salt water**)
- Installation in a cored fiberglass hull (see page 4):
 - Hole saw for hull interior: (see table on this page)
 - Fiberglass cloth and resin
 - or Cylinder, wax, tape, and casting epoxy

Identify Your Model

The model name is printed on the cable tag.

Model (Housing)	Minimum Headroom	Outside Hull Hole Saw Size	Cored Fiberglass Hull Hull Interior Hole Saw Size
Low Profile: B22, B117, P19, P319	95 mm (3-3/4")	51 mm or 2"	60 mm or 2-3/8"
P5	161 mm 6-3/8")	51 mm or 2"	60 mm or 2-3/8"
Flush: B21, P219, P269	100 mm (4")	51 mm or 2"	60 mm or 2-3/8"
Retractable: B17, B21 P17, P217, P314	200 mm (8")	51 mm or 2"	60 mm or 2-3/8"
Retractable: SS577	200 mm (8")	51 mm or 2" in a fiberglass or wood hull 57 mm or 2-1/4" in a metal hull	60 mm or 2-3/8"

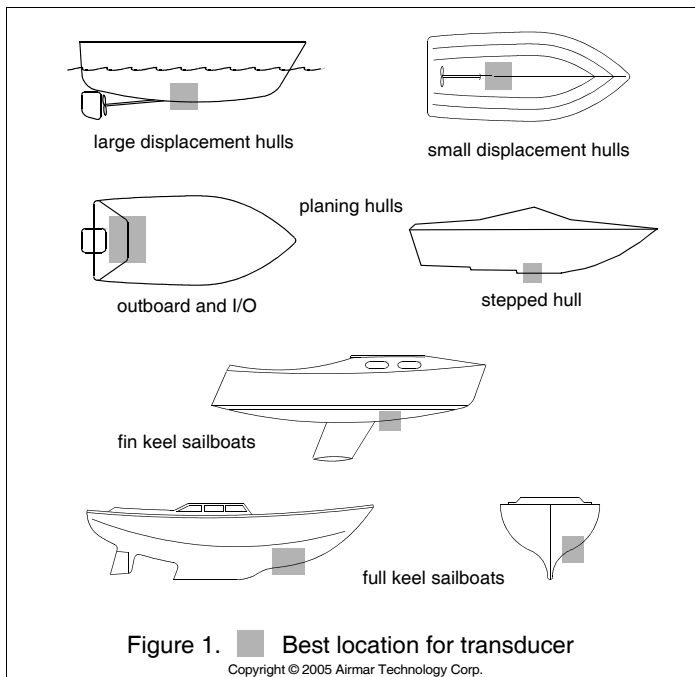

Mounting Location

CAUTION: Do not mount near water intake or discharge openings or behind strakes, fittings, or hull irregularities.

- The water flowing under the hull must be smooth with a minimum of bubbles and turbulence (especially at high speeds).
- The transducer must be continuously immersed in water.
- The transducer beam must be unobstructed by the keel or propeller shaft(s).
- Choose a location away from interference caused by power and radiation sources such as: the propeller(s) and shaft(s), other machinery, other echosounders, and other cables. The lower the noise level, the higher the echosounder gain setting that can be used.
- Choose a location with a minimal deadrise angle, so the transducer beam will be aimed at the bottom.
- Choose an accessible spot inside the vessel with adequate headroom for the height of the housing, tightening the nuts, and removing any insert (see the table below).

Hull Types (see Figure 1)

- **Displacement hull powerboats**—Locate amidships near the centerline. The starboard side of the hull where the propeller blades are moving downward is preferred.
- **Planing hull powerboats**—Mount well aft, on or near the centerline, and *well inboard of the first set of lifting strakes* to ensure that the transducer will be in contact with the water at high speeds. The starboard side of the hull where the propeller blades are moving downward is preferred.
- **Outboard and I/O**—Mount just forward of the engine(s).
- **Inboard**—Mount well ahead of the propeller(s) and shaft(s).
- **Stepped hull**—Mount just ahead of the first step.
- **Boat capable of speeds above 25 kn (29MPH)**—Review the installation location and operating results of similar boats before proceeding.
- **Fin keel sailboats**—Mount on or near the centerline and forward of the fin keel 300–600mm (1–2’).
- **Full keel sailboats**—Locate amidships and away from the keel at the point of minimum deadrise.

Installation

Hole Drilling

Cored fiberglass hull—Follow separate instructions on page 4.

1. Drill a 3 mm or 1/8" pilot hole from inside the hull. If there is a rib, strut, or other hull irregularity near the selected mounting location, drill from the outside.
2. Using the appropriate size *outside hull* hole saw, cut a hole perpendicular to the hull from outside the boat (see table on page 1).
Flush housing—Use a countersink tool to make a “seat” in the hull.
3. Sand and clean the area around the hole, inside and outside, to ensure that the marine sealant will adhere properly to the hull. If there is any petroleum residue inside the hull, remove it with either mild household detergent or a weak solvent (alcohol) before sanding.
Metal hull—Remove all burrs with a file and sandpaper.

Bedding

CAUTION; Be sure the surfaces to be bedded are clean and dry.

Apply a 2mm (1/16") thick layer of marine sealant around the flange of the housing that will contact the hull and up the sidewall of the housing (see Figure 2). The sealant must extend 6mm (1/4") higher than the combined thickness of the hull, washer, any spacer, and the hull nut. This will ensure there is sealant in the threads to seal the hull and to hold the hull nut securely in place.

Stainless steel housing in a metal hull—The stainless steel housing must be isolated from the metal hull to prevent electrolytic corrosion. Slide the isolation bushing onto the housing (see Figure 3). Apply *additional* marine sealant to the surfaces of the bushing that will contact the hull, filling any cavities in and around the bushing.

Installing

NOTE: Ignore any arrows on the housing, insert, and blanking plug.

1. From outside the hull, push the housing into the mounting hole using a twisting motion to squeeze out excess marine sealant.
2. From inside the hull, slide the washer onto the housing (see Figure 2).

B117 and P319—Also slide the spacer onto the housing and rest it against the washer. Do not use the spacer if there is insufficient space to tighten the nut or it is within 11 mm (1/2") of the top of the housing.

Aluminum hull less than 6mm (1/4") thick—If necessary, use an additional rubbery, fiberglass, or plastic washer. Never use bronze since electrolytic corrosion will occur. Never use wood since it will swell, possibly fracturing the plastic housing.

Stainless steel transducer in metal hull—Be sure the washer contacts the hull. Do not tighten the hull nut with the washer against the isolation bushing, as the housing will not be firmly installed. If necessary, sand the isolation bushing until the washer rests against the hull (see Figure 3).

3. Screw the hull nut in place.

Plastic housing—If your housing has wrenching flats, do not clamp tightly possibly causing the housing to fracture.

Plastic hull nut—**Hand tighten** only. Do not over tighten.

Metal hull nut—Tighten with slip-joint pliers.

Cored Fiberglass Hull—Do not over tighten, crushing the hull.

Wood hull—Allow the wood to swell before tightening the hull nut.

4. Remove any excess marine sealant on the outside of the hull to ensure smooth water flow over the transducer.

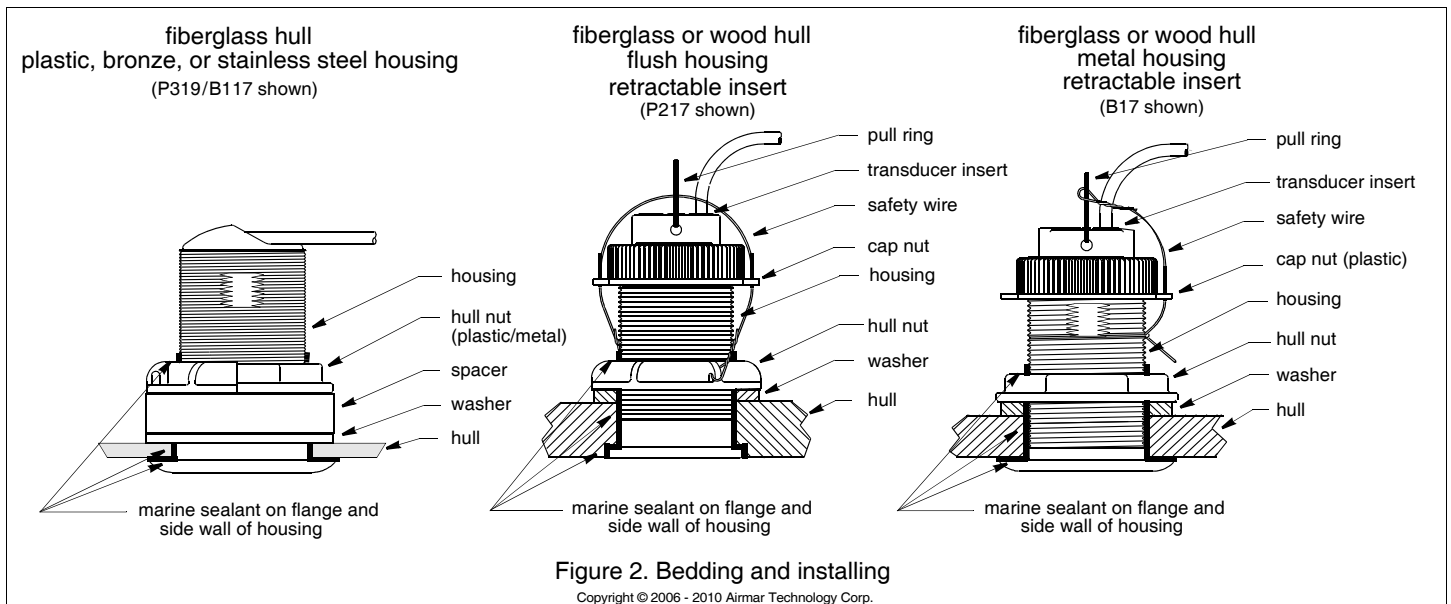

Figure 2. Bedding and installing
Copyright © 2006 - 2010 Airmar Technology Corp.

Retractable Models

1. After the marine sealant cures, inspect the O-rings on the transducer insert (replace if necessary) and lubricate them with the silicone lubricant supplied. The O-rings must be intact and well lubricated to make a watertight seal.
2. Slide the insert into the housing. Seat the insert into place with a twisting motion until the key fits into the notch. Be careful not to rotate the housing and disturb the marine sealant. Screw the cap nut in place and **hand tighten** only. Do not over tighten.

D/DT800—Be sure the insert is fully inserted into the housing. Screw the cap nut several turns until the threads are engaged. Continue to tighten the cap nut completely for a watertight seal.

3. Attach the safety wire to prevent the insert from backing out in the unlikely event that the cap nut fails or is screwed on incorrectly (see Figure 2 or 3).

Plastic housing—Attach the safety wire to one eye in the hull nut. Keeping the wire taut throughout, lead the wire in a counterclockwise direction and thread it through one eye in the cap nut, the pull ring/eye in the insert, the second eye in the cap nut, and the second eye in the hull nut. Twist the wire securely to itself.

Metal housing—Wrap one end of the safety wire tightly around the housing and twist it together with the long end. Keeping the wire taut throughout, lead the wire straight up and through the eye in the cap nut. Loop the wire through the pull ring/eye in the insert and twist it securely to itself.

Cable Routing & Connecting

CAUTION: If your transducer came with a connector, do not remove it to ease cable routing. If the cable must be cut and spliced, use Airmar’s splash-proof Junction Box No. 33-035 and follow the instructions provided. Removing the waterproof connector or cutting the cable, except when using a water-tight junction box, will void the sensor warranty.

1. Route the cable to the instrument, being careful not to tear the cable jacket when passing it through the bulkhead(s) and other parts of the boat. Use grommets to prevent chafing. To reduce electrical interference, separate the transducer cable from other electrical wiring and the engine. Coil any excess cable and secure it in place using cable ties to prevent damage.
2. Refer to the echosounder owner’s manual to connect the transducer to the instrument.

Checking for Leaks

When the boat is placed in the water, **immediately** check around the thru-hull transducer for leaks. Note that very small leaks may not be readily observed. Do not leave the boat in the water for more than 3 hours before checking it again. If there is a small leak, there may be considerable bilge water accumulation after 24 hours. If a leak is observed, repeat “Bedding” and “Installing” **immediately** (see page 2).

Installation in a Cored Fiberglass Hull

The core (wood or foam) must be cut and sealed carefully. The core must be protected from water seepage, and the hull must be reinforced to prevent it from crushing under the hull nut allowing the housing to become loose.

CAUTION: Completely seal the hull to prevent water seepage into the core.

1. Drill a 3 mm or 1/8" pilot hole from inside the hull. If there is a rib, strut, or other hull irregularity near the selected mounting location, drill from the outside. (If the hole is drilled in the wrong location, drill a second hole in a better location. Apply masking tape to the outside of the hull over the incorrect hole and fill it with epoxy.)

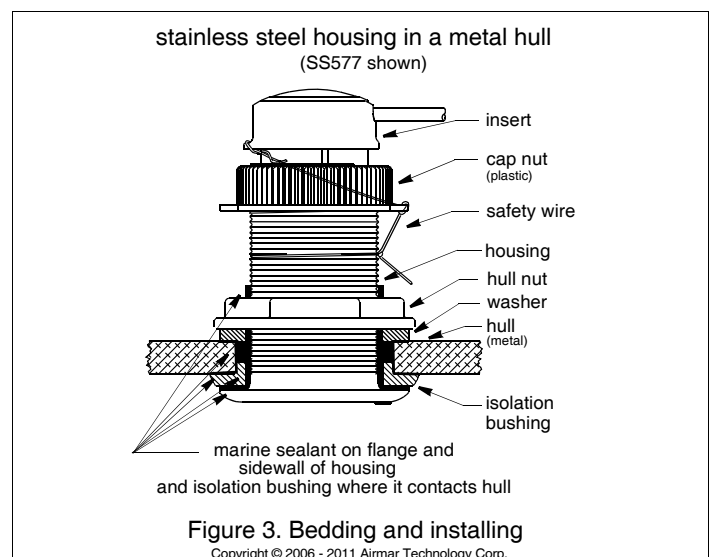
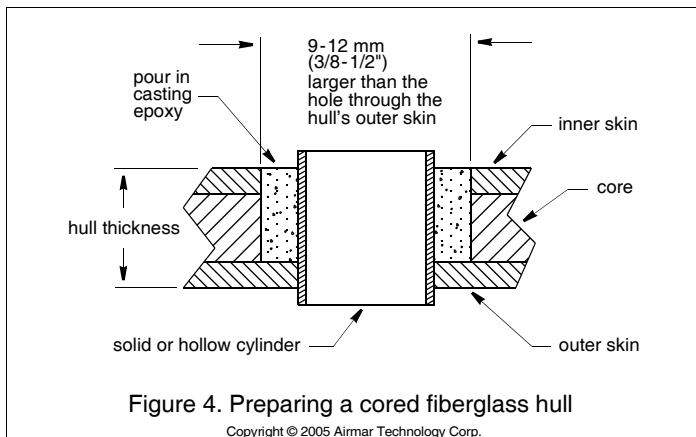

Figure 3. Bedding and installing
Copyright © 2006 - 2011 Airmar Technology Corp.



- Using the appropriate size *outside hull* hole saw, cut a hole from outside the hull through the *outer* skin only (see table on page 1) (see Figure 4).
- From inside the hull using the appropriate size *hull interior* hole saw, cut through the *inner* skin and most of the core (see table on page 1). The core material can be very soft. Apply only light pressure to the hole saw after cutting through the *inner* skin to avoid accidentally cutting the *outer* skin.
- Remove the plug of core material, so the *inside* of the outer skin and the inner core of the hull is fully exposed. Sand and clean the inner skin, core, and the outer skin around the hole.
- If you are skilled with fiberglass, saturate a layer of fiberglass cloth with a suitable resin and lay it inside the hole to seal and strengthen the core. Add layers until the hole is the correct diameter.
Alternatively, a hollow or solid cylinder of the correct diameter can be coated with wax and taped in place. Fill the gap between the cylinder and hull with casting epoxy. After the epoxy has set, remove the cylinder.
- Sand and clean the area around the hole, inside and outside, to ensure that the marine sealant will adhere properly to the hull. If there is any petroleum residue inside the hull, remove it with either mild household detergent or a weak solvent (alcohol) before sanding.
- Proceed with "Bedding" and "Installing" on page 2.

Maintenance, Parts & Replacement

Anti-fouling Paint

Surfaces exposed to salt water must be coated with anti-fouling paint. Use *water-based* anti-fouling paint only. Never use ketone based anti-fouling paint, since ketones can attack many plastics possibly damaging the transducer. Apply anti-fouling paint every 6 months or at the beginning of each boating season.

Retractable models—Paint the following surfaces:

- Outside wall of the insert below lower O-ring and exposed end
- Bore of the housing up 30mm (1-1/4")
- Exterior flange of the housing
- Blanking plug below the lower O-ring including the exposed end

Cleaning

Aquatic growth can accumulate rapidly on the transducer's surface, reducing its performance within weeks. Clean the surface with a Scotch-Brite® scour pad and mild household detergent, *being careful* to avoid making scratches. If the fouling is severe, lightly wet sand it with fine grade wet/dry paper.

Retractable Models: Blanking Plug

- The O-rings must be intact and well lubricated to make a watertight seal. On the blanking plug, inspect the O-rings (replace if necessary) and lubricate them with the silicone lubricant supplied or petroleum jelly (Vaseline®).

- Remove the transducer insert from the housing by removing the safety wire and unscrewing the cap nut (see Figure 2).
- With the blanking plug ready in one hand, pull the transducer insert most of the way out. Remove the insert and rapidly replace it with the blanking plug. Seat it into place with a pushing twisting motion until the key fits into the notch in the housing. With practice, only 250ml (10oz.) of water will enter the boat. Screw the cap nut in place and **hand tighten** only. Do not over tighten.
- D/DT800**—Being sure the blanking plug is fully inserted into the housing, screw the cap nut several turns until the threads are engaged. Continue to tighten the cap nut completely for a watertight seal. **Hand tighten** only. Do not over tighten.
- Reattach the safety wire to prevent the blanking plug from backing out in the unlikely event that the cap nut fails or is screwed on incorrectly.

Retractable Models: O-rings

O-rings must be free of abrasions and cuts to ensure a watertight seal. On the insert and blanking plug, inspect the O-rings (replace if necessary) and lubricate them with the silicone lubricant supplied or petroleum jelly (Vaseline®).

Retractable Models: Winterizing

After the boat has been hauled for winter storage, remove the blanking plug to let the water drain away before reinserting it. This will prevent any water from freezing around the blanking plug and possibly cracking it.

Replacement Transducer & Parts

The information needed to order a replacement Airmar transducer is printed on the cable tag. Do not remove this tag. When ordering, specify the part number, date, and frequency in kHz. For convenient reference, record this information on the top of page one.

Lost, broken, or worn parts should be replaced immediately.

D/DT800 O-rings 33-519-01

Model	Housing Kit, Washer, Spacer, or Isolation Bushing	Hull Nut	Cap Nut	Blanking Plug
B17 B21	33-100 (bronze, low profile) 33-224-01 (bronze, flush)	02-030	04-234-1 (plastic) 02-131-01 (bronze)	33-414
B22 B117	04-646-01 (spacer)	02-030	—	—
P5		04-002		
P17	33-417 (plastic, low profile)	04-004	04-234-1 (plastic)	33-414
P19 P219 P269	—	04-004	—	—
P217 P314	33-217 (plastic, flush) 33-092-01 (plastic, flush)	04-004	04-234-1 (plastic)	33-414
P319	04-646-01 (spacer)	04-004	—	—
SS577	33-495-01 (stainless steel, low profile) 04-186-1 (bushing)	20-570-01	04-234-1 (plastic)	33-414

Obtain parts from your instrument manufacturer or marine dealer.

Gemeco
(USA)

Tel: 803-693-0777
Fax: 803-693-0477
email: sales@gemeco.com

Airmar EMEA
(Europe, Middle East, Africa)

Tel: +33.(0)2.23.52.06.48
Fax: +33.(0)2.23.52.06.49
email: sales@airmar-emea.com

AIRMAR®
TECHNOLOGY CORPORATION

35 Meadowbrook Drive, Milford, New Hampshire 03055-4613, USA

www.airmar.com

Copyright © 2006 - 2011 Airmar Technology Corp. All rights reserved.