

# BRONZE RUBBER IMPELLER PUMP



**OBERDORFER PUMPS**  
A Subsidiary of Thomas Industries Inc.

**MODEL**  
**202M**  
**202M-03**  
**202M-07**  
**202M-15**  
**202M-16**

## RUBBER IMPELLER PUMP N202M /N202M-03/N202M-07

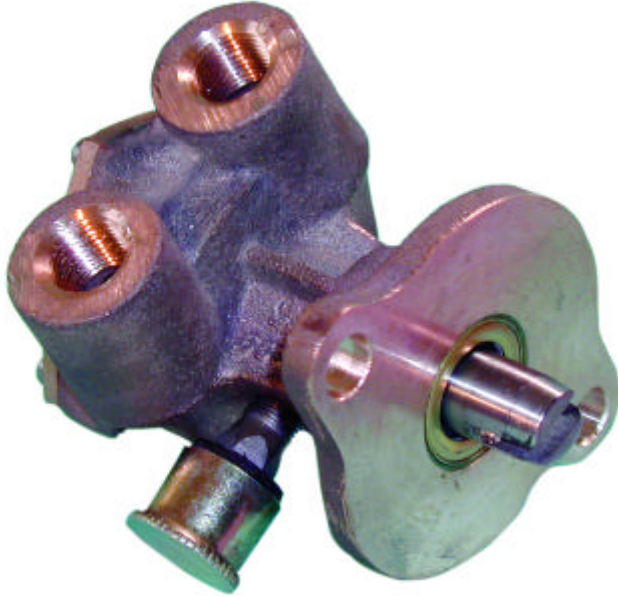

## RUBBER IMPELLER PUMP N202M-15/N202M-16

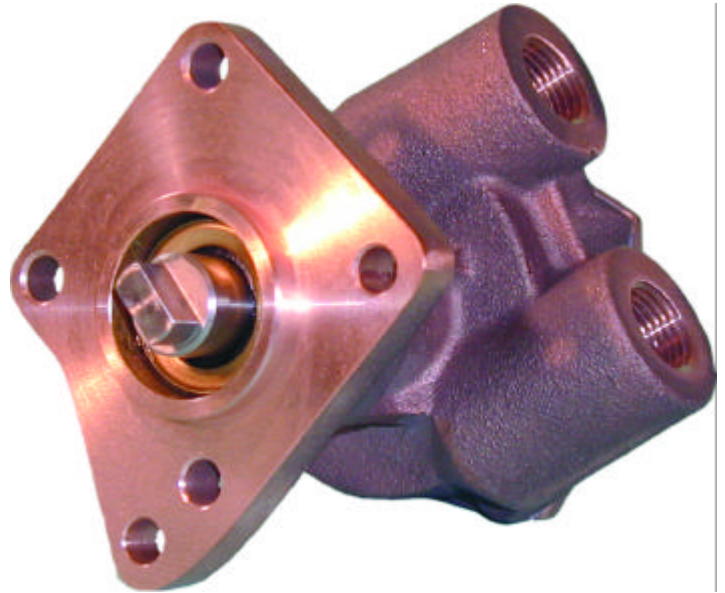

### FEATURES

- Rugged simplicity
- Corrosion Resistant
- Convenient drain plug
- 2 bolt or 5 bolt flange mounting
- Slotted shaft drive or male tang drive
- 2 separate seals: main pump and flange mounting
- “Up” direction in & out ports
- High chrome nickel stainless steel shaft
- Impeller easily replaced
- Machined in cam

### ROTATION

Direction of shaft rotation determines inlet and outlet ports (see line dimension drawing). Prior to installation, rotate the pump manually in direction of rotation to set flexible blades in direction desired.

### DO NOT RUN DRY

Rubber impellers generate high rubbing friction unless lubricated by liquid pumped. Lack of liquid will cause impeller to burn up.

### PERFORMANCE

WATER AT 60°F

PUMP	RPM	FT. HD	0	10	20	30	40	50	60
		PSI	0	4.3	8.7	13	17.3	21.7	26
N202M N202M-07 N202M-15 N202M-16	1750	GPM	6 1/2	6 1/4	6	5 1/2	4 3/4	4	2 3/4
		HP	1/3	1/3	1/3	1/3	1/3	1/3	1/3
	2500	GPM	9 1/2	9 1/4	9	8 1/4	7 1/2	6 1/2	5 1/4
		HP	1/2	1/2	1/2	1/2	1/2	1/2	1/2
	3500	GPM	12 1/2	12 1/4	11 1/2	11	10	9	8
		HP	3/4	3/4	3/4	3/4	3/4	3/4	3/4
N202M-03	1750	GPM	3 3/4	3 1/4	2 1/2	2	1	–	–
		HP	1/3	1/3	1/3	1/3	1/3	–	–
	2500	GPM	6 1/2	6	5 1/2	4 1/2	3 1/2	2	1/4
		HP	1/2	1/2	1/2	1/2	1/2	1/2	1/2
	3500	GPM	9 1/4	8 3/4	8 1/4	7	5 1/2	4	1 3/4
		HP	3/4	3/4	3/4	3/4	3/4	3/4	3/4

RPM= REVOLUTIONS PER MINUTE  
GPM= GALLONS PER MINUTE  
PSI= LBS. PER SQUARE INCH PRESSURE  
FT. HD.= FEET HEAD PRESSURE

# BRONZE RUBBER IMPELLER PUMP

MODEL 202M 202M-03 202M-07 202M-15 202M-16

## DESIGN SPECS

Model	Ports	Cam	Flange	Shaft	Designed for	Universal #
N202M	1/2 -14 FNPT	full	2 bolt	5/8" with 7/32" slot		
N202M-03	3/8 -18 FNPT	half	2 bolt	5/8" with 7/32" slot	Universal Atomic-4 Series Gas and Diesel Marine Engine	299805
N202M-07	3/8 -18 FNPT	full	2 bolt	5/8" with 7/32" slot	Universal Atomic-4 Series Gas and Diesel Marine Engine	299805
N202M-15	3/8 -18 FNPT	full	5 bolt with male pilot	male tang	Universal Series with Kubota Diesel	301357
N202M-16	1/2 -14 FNPT	full	5 bolt with male pilot	male tang		

## UNIVERSAL ENGINE DATA

Pump	Universal Model	Horsepower	Cylinders	Block Model
N202M-03	Atomic 4			
N202M-07	M-15	11	2	Z-500
N202M-15	M-12	10	2	Z-400
N202M-15	M-18	14	2	Z-600
N202M-15	M-25XP	23	3	D-950
N202M-15	M-30	24	3	D-1101
N202M-15	M-30	24	3	D-1102
N202M-15	M-50	44	2	V-1902

## KUBOTA ENGINE DATA

Pump	Kubota Model	Horsepower	Cylinders	Displacement
N202M-16	Z482E	13.5	2	479 cc
N202M-16	D722E	20.5	3	719 cc
N202M-16	V1903E	42	4	1857 cc
N202M-16	V2203E	49.5	4	2197 cc

## LIQUIDS AND TEMPERATURE

Liquids compatible with neoprene can be pumped including fresh and salt water solutions and mild chemicals. Do not pump gasoline, severe solvents or acids. When possible flush pump with fresh water after each usage.

Buna (Nitrile) impellers can handle oil contaminated water and kerosene at reduced impeller service life.

Extremes of cold and heat will affect impeller life. Limits of 40°F to 140°F should be observed. Do not allow liquid in pump to freeze. Drain pump by removing drain plug provided. Located at bottom of pump body. Use methyl alcohol based anti-freeze compounds.

## SUCTION LIFT

On initial start-up pump must be primed to prevent dry-running of the impeller. Suction lift of 15 ft. is possible when impeller is wet and pump fully primed. Suction lines must be air tight in order for pump to self prime.

# BRONZE RUBBER IMPELLER PUMP

MODEL 202M 202M-03 202M-07 202M-15 202M-16

## EXPLODED VIEW AND PARTS LIST

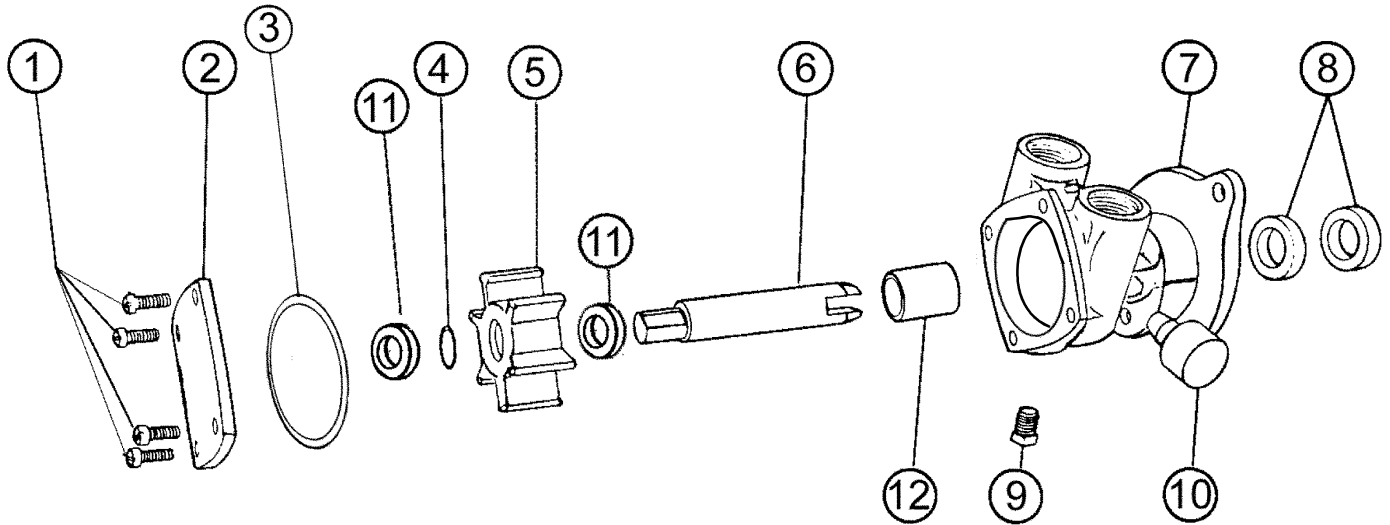

Model	Item	1	2	3	4	5	6	7	8	9	10	11	12	Repair Kit <sup>4</sup>
	Name	Screw	Cover	O-Ring	Snap Ring	Impeller <sup>1</sup>	Shaft	Body	Lip Seal <sup>2</sup>	Plug	Grease Cup <sup>3</sup>	Washer	Carbon Bearing	
	Required	4	1	1	1	1	1	1	2	1	1	2	1	
N202M		5385	6597B	9797-034	5373	6593	6598	6595-1	5463	6600	5910			10725
N202M-03		5385	6597B	9797-034	5373	6593	6598	6892-2	5463	6600	5910			10725
N202M-07		5385	6597B	9797-034	5373	6593	6598	6892-1	5463	6600	5910			10725
N202M-15		5385	6597B	9797-034	5373	6593	8767	8920-1C	5463	6600		9647	5091	11691
N202M-16		5385	6597B	9797-034	5373	6593	8767	9879-1C	5463	6600		9647	5091	11691

- Notes:
- 1 Neoprene impeller is standard, optional Buna impeller (8514) available
  - 2 Brass case, buna elastomer
  - 3 Pumps equipped with pre-filled grease cups from the factory, N202M, N202M-03, N202M-07
  - 4 Kits contain items 3,4,5, 8 and (when applicable) 12 and gaskets for older models
  - 5 Body P/N is a sub-assy that also includes item 12, carbon bearing (when applicable)

**MODEL**  
**202M**  
**202M-03**  
**202M-07**  
**202M-15**  
**202M-16**

# BRONZE RUBBER IMPELLER PUMP

ENGINE MOUNT



## OBERDORFER PUMPS

*A Subsidiary of Thomas Industries Inc.*

### N202M, N202M-03, N202M-07 DIMENSIONS

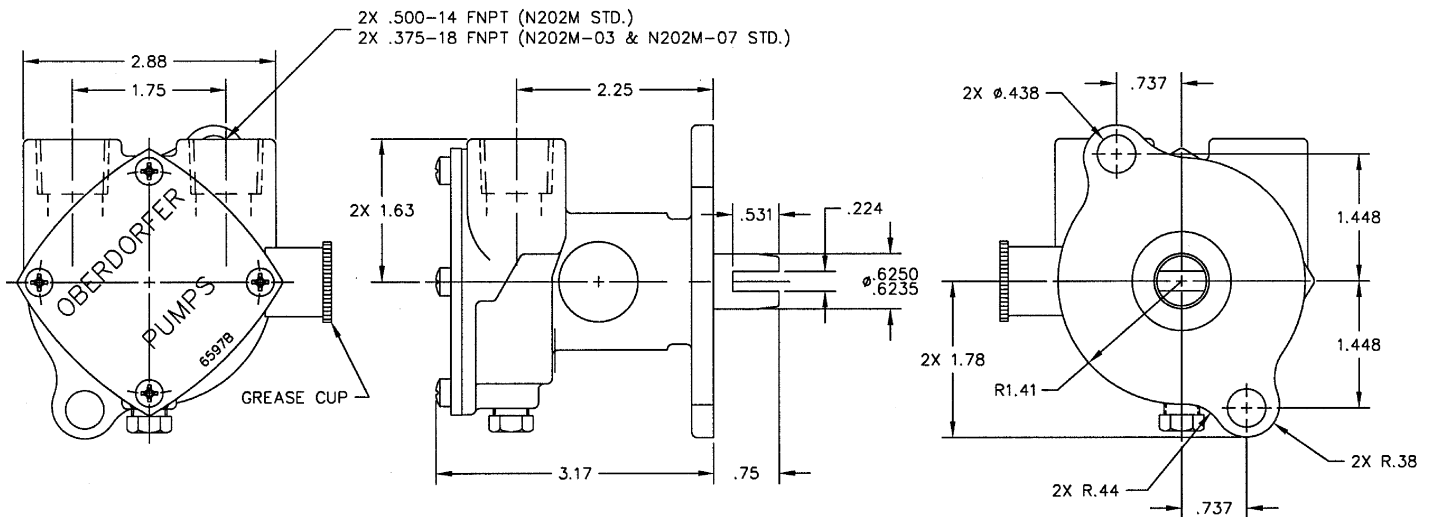

### ROTATIONAL



ROTATION DIAGRAM LOOKING AT COVER

### N202M-15, N202M-16 DIMENSIONS

